

marantz®

Model SD4050 User Guide

Cassette Deck

IMPORTANT TO SAFETY

WARNING:

TO PREVENT FIRE OR SHOCK HAZARD, DO NOT EXPOSE THIS APPLIANCE TO RAIN OR MOISTURE.

CAUTION:

1. Handle the power supply cord carefully

Do not damage or deform the power supply cord. If it is damaged or deformed, it may cause electric shock or malfunction when used. When removing it from wall outlet, be sure to remove by holding the plug attachment and not by pulling the cord.

2. Do not open the top cover

In order to prevent electric shock, do not open the top cover. If problems occur, contact your **MARANTZ DEALER**.

3. Do not place anything inside

Do not place metal objects or spill liquid inside the cassette tape deck.

Electric shock or malfunction may result.

Please, record and retain the Model name and serial number of your set shown on the rating label.

Model No. SD4050 Serial No. _____

● FOR U.S.A. & CANADA MODEL ONLY

CAUTION

TO PREVENT ELECTRIC SHOCK DO NOT USE THIS (POLARIZED) PLUG WITH AN EXTENSION CORD, RECEPTACLE OR OTHER OUTLET UNLESS THE BLADES CAN BE FULLY INSERTED TO PREVENT BLADE EXPOSURE.

● POUR LES MODELES AMERICAINS ET CANADIENS UNIQUEMENT

ATTENTION

POUR PREVENIR LES CHOCS ELECTRIQUES NE PAS UTILISER CETTE FICHE POLARISEE AVEC UN PROLONGATEUR UNE PRISE DE COURANT OU UNE AUTRE SORTIE DE COURANT, SAUF SI LES LAMES PEUVENT ETRE INSEREES A FOND SANS EN LAISSER AUCUNE PARTIE A DECOUVERT.



CAUTION
RISK OF ELECTRIC SHOCK
DO NOT OPEN



CAUTION:

TO REDUCE THE RISK OF ELECTRIC SHOCK, DO NOT REMOVE COVER (OR BACK). NO USER SERVICEABLE PARTS INSIDE. REFER SERVICING TO QUALIFIED SERVICE PERSONNEL.



The lightning flash with arrowhead symbol within an equilateral triangle is intended to alert the user of the presence of uninsulated "dangerous voltage" within the product's enclosure that may be of sufficient magnitude to constitute a risk of electric shock to persons.



The exclamation point within an equilateral triangle is intended to alert the user of the presence of important operating and maintenance (servicing) instruction in the literature accompanying the appliance.

SAFETY INSTRUCTIONS

READ BEFORE OPERATING EQUIPMENT

This product was designed and manufactured to meet strict quality and safety standards. There are, however, some installation and operation precautions which you should be particularly aware of.

1. **Read Instructions** – All the safety and operating instructions should be read before the appliance is operated.
2. **Retain Instructions** – The safety and operating instructions should be retained for future reference.
3. **Heed Warnings** – All warnings on the appliance and in the operating instructions should be adhered to.
4. **Follow Instructions** – All operating and use instructions should be followed.
5. **Water and Moisture** – The appliance should not be used near water—for example, near a bathtub, washbowl, kitchen sink, laundry tub, in a wet basement, or near a swimming pool, and the like.
6. **Carts and Stands** – The appliance should be used only with a cart or stand that is recommended by the manufacturer.
- 6A. An appliance and cart combination should be moved with care. Quick stops, excessive force, and uneven surfaces may cause the appliance and cart combination to overturn. 
7. **Wall or Ceiling Mounting** – The appliance should be mounted to a wall or ceiling only as recommended by the manufacturer.
8. **Ventilation** – The appliance should be situated so that its location or position does not interfere with its proper ventilation. For example, the appliance should not be situated on a bed, sofa, rug, or similar surface that may block the ventilation openings; or, placed in a built-in installation, such as a bookcase or cabinet that may impede the flow of air through the ventilation openings.
9. **Heat** – The appliance should be situated away from heat sources such as radiators, heat registers, stoves, or other appliances (including amplifiers) that produce heat.
10. **Power Sources** – The appliance should be connected to a power supply only of the type described in the operating instructions or as marked on the appliance.
11. **Grounding or Polarization** – Precautions should be taken so that the grounding or polarization means of an appliance is not defeated.
12. **Power-Cord Protection** – Power-supply cords should be routed so that they are not likely to be walked on or pinched by items placed upon or against them, paying particular attention to cords at plugs, convenience receptacles, and the point where they exit from the appliance.
14. **Cleaning** – The appliance should be cleaned only as recommended by the manufacturer.
15. **Power Lines** – An outdoor antenna should be located away from power lines.
16. **Outdoor Antenna Grounding** – If an outside antenna is connected to the receiver, be sure the antenna system is grounded so as to provide some protection against voltage surges and built-up static charges. Article 810 of the National Electrical Code, ANSI/NFPA 70, provides information with regard to proper grounding of the mast and supporting structure, grounding of the lead-in wire to an antenna-discharge unit, size of grounding conductors, location of antenna-discharge unit, connection to grounding electrodes, and requirements for the grounding electrode. See Figure A.
17. **Nonuse Periods** – The power cord of the appliance should be unplugged from the outlet when left unused for a long period of time.
18. **Object and Liquid Entry** – Care should be taken so that objects do not fall and liquids are not spilled into the enclosure through openings.
19. **Damage Requiring Service** – The appliance should be serviced by qualified service personnel when:
 - A. The power-supply cord or the plug has been damaged; or
 - B. Objects have fallen, or liquid has been spilled into the appliance; or
 - C. The appliance has been exposed to rain; or
 - D. The appliance does not appear to operate normally or exhibits a marked change in performance; or
 - E. The appliance has been dropped, or the enclosure damaged.
20. **Servicing** – The user should not attempt to service the appliance beyond that described in the operating instructions. All other servicing should be referred to qualified service personnel.

NOTE ON USE / OBSERVATIONS RELATIVES A L'UTILISATION

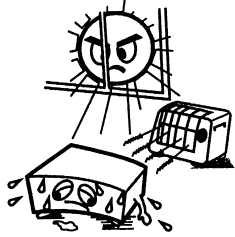

- Avoid high temperatures
Allow for sufficient heat dispersion when installed on a rack.
- Eviter des températures élevées
Tenir compte d'une dispersion de chaleur suffisante lors de l'installation sur une étagère.



- Keep the set free from moisture, water, and dust.
- Protéger l'appareil contre l'humidité, l'eau et la poussière.

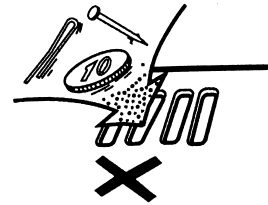

- Do not let foreign objects in the set.
- Ne pas laisser des objets étrangers dans l'appareil.

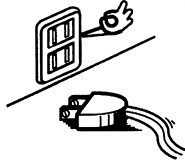

- Unplug the power cord when not using the set for long periods of time.
- Débrancher le cordon d'alimentation lorsque l'appareil n'est pas utilisé pendant de longues périodes.

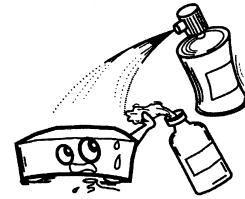

- Do not let insecticides, benzene, and thinner come in contact with the set.
- Ne pas mettre en contact des insecticides, du benzène et un diluant avec l'appareil.

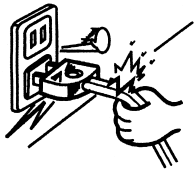

- Handle the power cord carefully.
Hold the plug when unplugging the cord.
- Manipuler le cordon d'alimentation avec précaution.
Tenir la prise lors du débranchement du cordon.

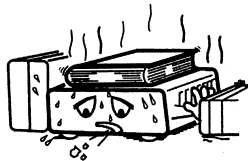

*(For sets with ventilation holes)

- Do not obstruct the ventilation holes.
- Ne pas obstruer les trous d'aération.

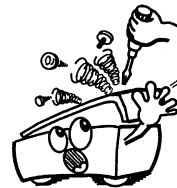

- Never disassemble or modify the set in any way.
- Ne jamais démonter ou modifier l'appareil d'une manière ou d'une autre.

Thank you very much for purchasing the MARANTZ component stereo cassette tape deck.
 MARANTZ proudly presents this advanced tape deck to audiophiles and music lovers as a further proof of MARANTZ's non-compromising pursuit of the ultimate in sound quality. The high quality performance and easy operation are certain to provide you with many hours of outstanding listening pleasure.

— TABLE OF CONTENTS —

FEATURES 5
 CONNECTION 5
 NAMES AND FUNCTIONS OF PARTS 6, 7
 CASSETTE TAPES 7
 AUTOMATIC TAPE SELECTION 8
 PLAYBACK 8
 RELAY PLAY 9
 RECORDING 9
 PROPER RECORDING LEVEL 10
 REC MUTE AND REC PAUSE BUTTON 10
 DUBBING 10
 SYNCRO REVERSE DUBBING 11
 TAPE COUNTER 11
 DOLBY B AND C NOISE REDUCTION SYSTEM 11
 DOLBY HX PRO HEADROOM EXTENSION SYSTEM 12
 MAINTENANCE 12
 REMOTE CONTROL 13
 USING THE REMOTE CONTROL UNIT 13
 TROUBLE SHOOTING 14
 SPECIFICATIONS 14

Please check to make sure the following items are included with the main unit in the carton:

- (1) Operating Instructions 1
- (2) Stereo audio cable 2
- (3) Remote control unit (RC455SD) 1
- (4) AA (R6) Batteries 2

FEATURES

- Computer Controlled Mechanism
- Dolby HX-Pro Headroom Extension System
- Dolby B & C Noise Reduction Systems
- Dual Computing Tape Counter with 4-Digit Readout
- FL Peak Level Meters
- Auto Tape Selector
- 2-Speed Dubbing
- Relay Playback
- Remote Controllable
- Pitch Control Function (DECK A)

CONNECTION

- Leave your entire system (including this cassette deck) turned off until all connections between the deck and other components have been completed.

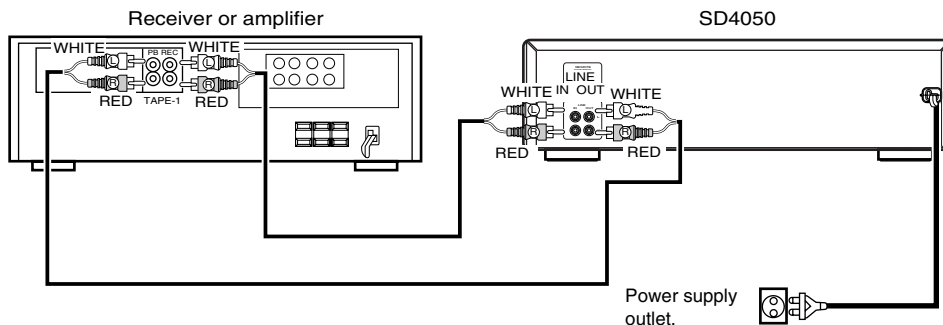

■ **Connecting the Deck to an Amplifier**

- Before connecting the deck to your amplifier, please review your amplifier's instruction manual.
- Use the white plugs for the left channel and red plugs for the right channel.

■ **Tape Dubbing**

- Many stereo amplifiers and receivers have tape dubbing circuitry so that tape duplication can be performed between two or more tape decks. Review your amplifier's instruction manual for a full explanation of this mode of operation.

■ **Connecting Headphones**

To listen through headphones, plug your headphones into the PHONES jack.

■ **REMOTE CONTROL**

For the operation of the system remote control. The following functions of this Marantz product can be remote-controlled.

Play, FF, REW, Stop, Rec, Rec Pause, Rec Mute, Counter Reset, Direction, Deck A, Deck B.

However, the remote-controllable functions are dependent on the type of remote control used.

If this Marantz product is to be remote-controlled by a Marantz Learning Remote Control, please refer to the Command Code Table of page 12 at the end of this manual.

■ **Installation Precautions**

If the deck is placed near an amplifier, TV or tuner, noise (induced hum) or beat interference may result, especially during FM or AM reception. If this occurs, place the deck further away from other components or reorient its position.

Caution

A mechanical sound is heard the first time the power switch is set to "ON" after the power cord is plugged into an outlet. This is the sound of the cassette mechanism being set to the proper operating state, and is normal.
 (When using an AC outlet on a receiver or amplifier, used an "UNSWITCHED" outlet.)

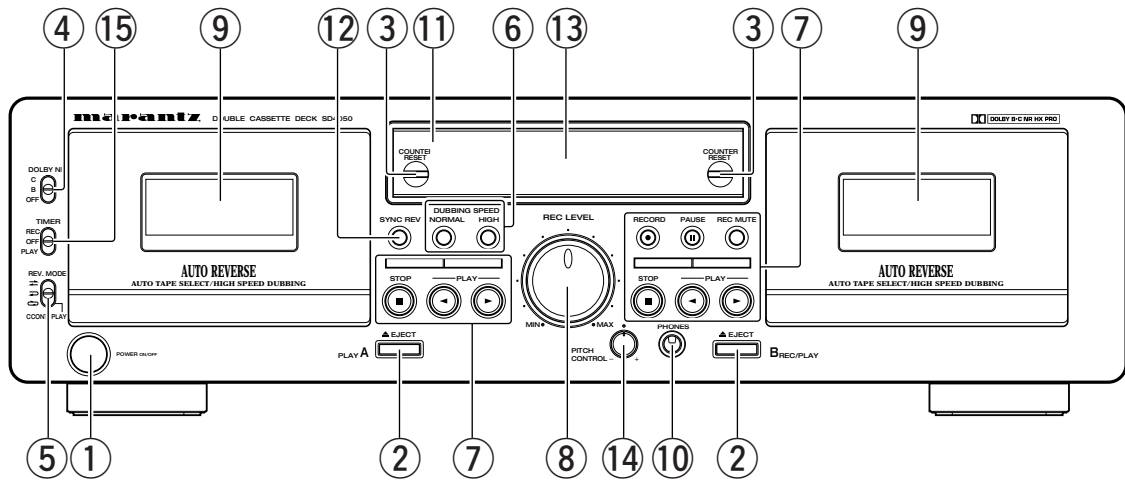

① **Power Switch (POWER)**

Press once to turn the power to deck on, and once more to turn the power off. The deck remains in a standby (non-operative) mode for approximately 2 seconds after it is switched on.

② **Eject Button (▲ EJECT)**

Press this button to open the cassette compartment cover. When the tape is running, press the STOP (■) button first to stop tape transport, then press the Eject button.

③ **Counter Reset Button (COUNTER RESET)**

Press this button to reset the tape counter to zero.

⑦ **Tape Transport Buttons**

▶ (PLAY)	Forward Play Button	Press to Forward playback tape.
◀ (PLAY)	Reverse Play Button	Press to Reverse playback tape.
■ (STOP)	Stop Button	Press to stop the tape in any mode.
◀◀ (REW)	Fast Rewind Button	Press for fast rewind.
▶▶ (FF)	Fast Forward Button	Press for fast forwarding
● (REC) (Deck B only)	Rec Button	Press the REC button and PLAY button simultaneously to start recording. If only the REC button is pressed, the deck enters the Recording Pause mode.
REC MUTE (Deck B only)	Rec Mute Button	Pressing this button in the Recording Pause mode will start Auto Rec Mute, and a 4-second silent space is recorded onto the tape. See page 10.
(PAUSE) (Deck B only)	Rec Pause Button	Press this button to enter the recording pause mode from the recording or recording mute mode. This button can only be used during recording. See page 10.

⑧ **Rec Level Control (REC LEVEL)**

This knob adjusts the recording input level. It affects the level in both channels. See page 9.

⑨ **Cassette Compartment Cover**

If the cover is not closed completely, the tape transport buttons will remain inoperative.

⑩ **Headphone Jack (PHONES)**

For private music enjoyment without disturbing others, or for monitoring a recording, a headphone set may be connected to this jack. Use a headphone with an impedance rating of 8 to 1200 ohms.

④ **Dolby NR Switch (DOLBY NR)**

To record or playback tapes with Dolby B or C-type noise reduction, set this switch to "B" or "C". Turn it "OFF" when not using the Dolby NR system.

⑤ **Reverse Mode Switch (REV MODE)**

Select the tape of tape transport. The reverse mode can be set to → (one side), ↔ (both side), ↻ (continuous playback).

⑥ **Dubbing Speed Buttons (DUBBING SPEED)**

Pressing the NORMAL button starts regular speed dubbing from deck A to deck B. Press the HIGH button to perform dubbing at double speed. See page 10.

⑪ **Remote Sensor**

Each of "PLAY, FF, REW, STOP, REC, REC PAUSE, REC MUTE, DIRECTION, COUNTER RESET, DECK A and DECK B" functions can be remote controlled with wireless handset.

NOTE:

Note that only the A deck can be operated with remote control units which have no A/B selector button.

⑫ **Syncro Reverse (SYNC REV)**

Press this button to set the SYNC REV mode. See page 11.

- ⑬ **Display**
Indicators with an encircled number light up when the corresponding button is pressed.

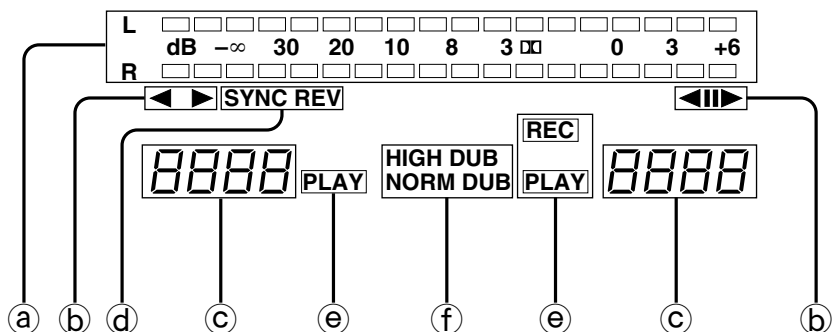

- Ⓐ Peak Level Meter
- Ⓑ Direction & Pause Indicators
- Ⓒ Multi Counter
- Ⓓ SYNC REV Indicator
- Ⓔ Mode Indicators
- Ⓕ Dubbing Indicators

- ⑭ **PITCH CONTROL Knob**
Used to vary the pitch (key of music) during playback of a cassette. (Only the pitch of Deck A can be varied.)
Turn the PITCH CONTROL clockwise to heighten the pitch by increasing the tape transport speed.
Turn it counterclockwise to lower the pitch by decreasing the tape transport speed.

- ⑮ **TIMER Switch (TIMER playback/TIMER recording)**
The select switch for use in timer playback or timer recording using an audio timer.
Set this switch to the OFF position when timer playback or timer recording is not required.

CASSETTE TAPES

■ **Handling Precautions**

- C-120 Cassettes
C-120 cassette tapes are not recommended as they use a very thin tape base which may become tangled around the capstan or pinch roller.
- Tape Slack
Before putting a tape into the deck, take up any slack with a pencil or your finger tip. This precaution prevents the tape from becoming entangled around the capstan or pinch roller.

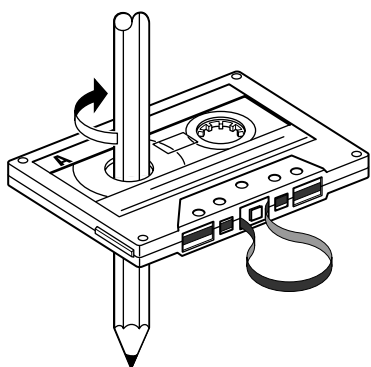

■ **Storage Precautions**

- Do not store cassette tapes in a place where they will be subject to:
 - Extremely high temperature or excessive moisture
 - Excessive dust
 - Direct sunlight
 - Magnetic fields (near TV sets or speakers)
- To eliminate tape slack, store your cassettes in cassette cases with hub stops

■ **Accidental Erasure Prevention**

- All cassettes have erasure prevention tabs for each side. To protect valuable recordings from accidental or inadvertent erasure, remove the tab for the appropriate side with a screwdriver or another tool.
- To record on a tape whose erasure prevention tabs have been removed, cover the tab holes with adhesive tape.

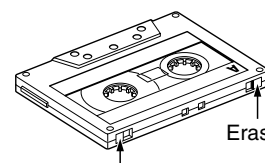

AUTOMATIC TAPE SELECTION

This Stereo Cassette Deck contains an automatic tape selector which automatically selects the optimum bias and equalization for the tape in use. This is accomplished by detection of tape type detection holes in the cassette housing.

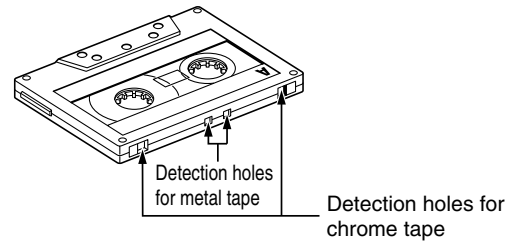

- If a tape without tape type detection holes is used, the deck will be set for normal tapes.

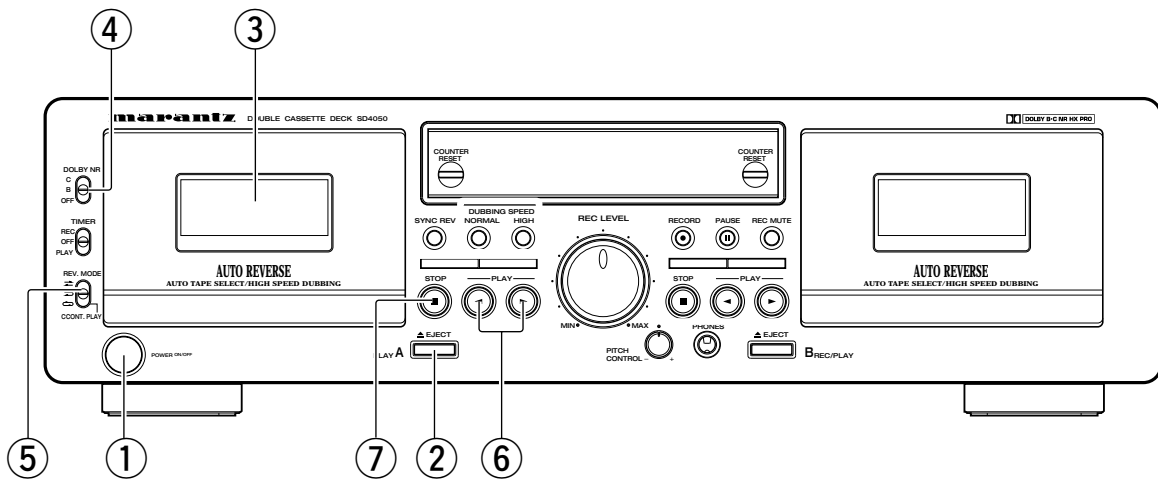

PLAYBACK

- The operations described below apply to deck A and deck B alike.
- Switch on your amplifier or receiver.
- Set the Function Selector on your amplifier or receiver to the TAPE or Tape monitor position.
- The numbers in the illustration below depict the order in which operation steps are carried out.







1. Press the **POWER** switch ① to the ON () position.
2. Press the **EJECT** () button ② to open the cassette compartment cover ③.
3. Load the cassette tape and close the cassette compartment cover ③.
4. When listening to a tape that has been recorded with Dolby noise reduction, set the **DOLBY NR** switch ④ to match the system used at the time of recording.









5. Select the type of tape transport with the **REV MODE** switch ⑤.



6. Press the **PLAY** button ⑥ ( or ) to begin playback.

Transport Direction	Indicator
Forward	
Reverse	

7. Press the **STOP** () button ⑦ to stop the playback.
 - In the continuous playback mode (REV MODE set to ), playback of both tape sides will be repeated 5 times and then stop automatically.
 - If different types of Dolby noise reduction are used for record and playback, playback response will be adversely effected.
 - When power is turned off during tape transport, it may not be possible to remove the cassette by pressing the **EJECT** () button. In this case, turn on power again before you press the **EJECT** () button.

Mode	Switch position
To listen to one side only	
To listen to playback of both sides	
To listen to continuous play back of both sides and both decks.	

■ **RELAY PLAY** (continuous playback of the tapes in deck A and deck B)

- Load a cassette tape into deck A and B, and set the **Dolby NR** button correctly.

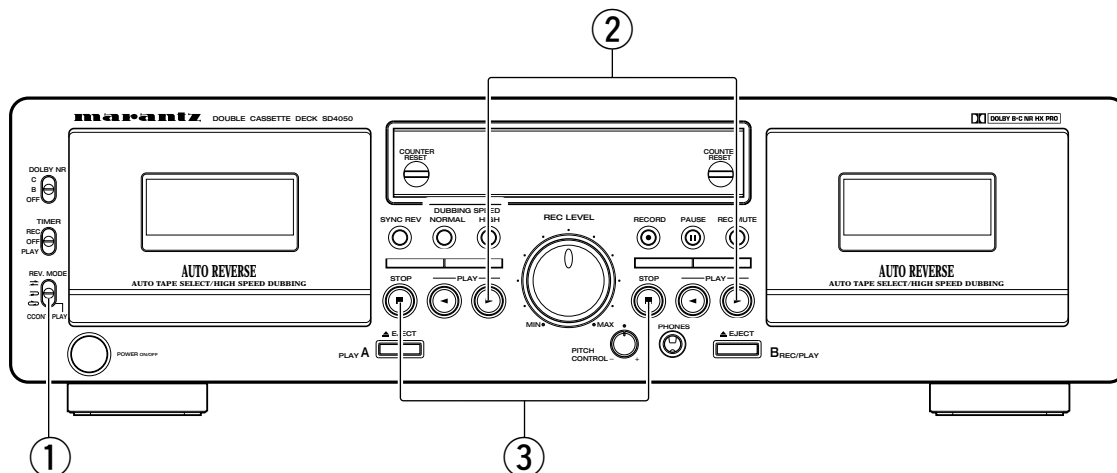

1. REV MODE set to ①.
2. Press the **PLAY** button ② of the deck you first wish to listen to.
3. To stop relay play, press the stop (■) ③ of the deck currently playing the tape.
 - Relay play will play deck A and B in succession for 5 times, (Deck A → Deck B → Deck A → Deck B → Deck A) or (Deck B → Deck A → Deck B → Deck A → Deck B).

RECORDING (DECK B only)

- Switch on your amplifier or receiver and the source component.
- Set the Function Selector or Tape monitor on your amplifier or receiver to the **SOURCE** or **Tape monitor OFF** position.

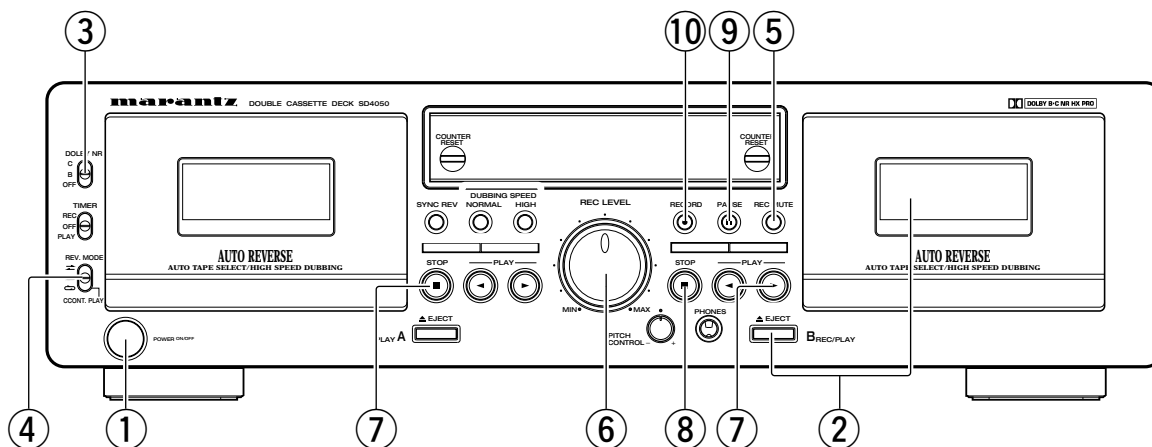

1. Press the **POWER** switch ① to the ON (■) position.
2. Load the cassette tape ②.
(Check that the erasure prevention tabs of the cassette housing have not been broken off.)
3. Press the **DOLBY NR** switch ③ and select the Dolby NR type that suits the recording.
4. Select the type of tape transport with the **REV MODE** switch ④.
5. Press the **REC** button ⑩ to set the recording pause mode. The **REC** and **||** indicator will light up.
6. Adjust the recording level with the **REC LEVEL** control ⑥ while watching the Peak Level Meter.
7. Press the **PLAY** (▶) button ⑦ to start the recording. The **PLAY** and the **REC** Indicator will light during recording.
8. To pause the recording, press the **PAUSE** (||) button ⑨. Press the **PLAY** ⑦ or **PAUSE** button ⑨ to resume recording.
9. To stop recording, press the **STOP** (■) button ⑧.



4. Select the type of tape transport with the **REV MODE** switch ④.

Mode	Switch position
To record on only one side	
To continuously record on both sides	or

Caution:

- Be careful not to erase important recordings by mistake. Inadvertent start of recording will happen in the following cases:
 1. If the **PLAY** button is pressed while the **REC** indicator lights, recording starts.
 2. If the **PLAY** and ● **REC** button are pressed at the same time, recording starts.
 The best way to avoid accidental erasure is to break off the two erasure prevention tabs on the cassette housing.

PROPER RECORDING LEVEL

A too high recording level can saturate the tape and cause distortion. On the other hand, if the recording level is set too low, soft passages will be marked by residual noise. A proper recording level is the single most important factor for making well balanced recordings.

Guideline for maximum recording level

TYPE I (Normal)	0 dB level on peaks
TYPE II (High position)	+1 dB level on peaks
TYPE IV (Metal)	+3 dB level on peaks

Note:

The optimum recording level differs depending on the program source and the type of tape used.

REC MUTE AND REC PAUSE BUTTON

- To record a 4-second blank section during recording:
Press the **REC MUTE** button. A 4-second blank will be recorded and the deck will enter the recording Pause mode.
- To record a 4-second blank section during the recording Pause mode:
Press the **REC MUTE** button from the recording Pause mode. A 4 second blank will be recorded and the deck will enter the recording Pause mode again.
- To cancel recording of blank space:
Press the **PAUSE (|||)** button. Blank space recording will be canceled and the deck enters the recording Pause mode.
- To extend the blank section with another 4 seconds or more:
Simply press the **REC MUTE** button and the blank section will be increased with another 4 seconds.

DUBBING (from deck A to deck B)

- Switch on the amplifier or receiver.
- Set the Tape Monitor or Function switch on your amplifier or receiver to the TAPE/TAPE monitor position.

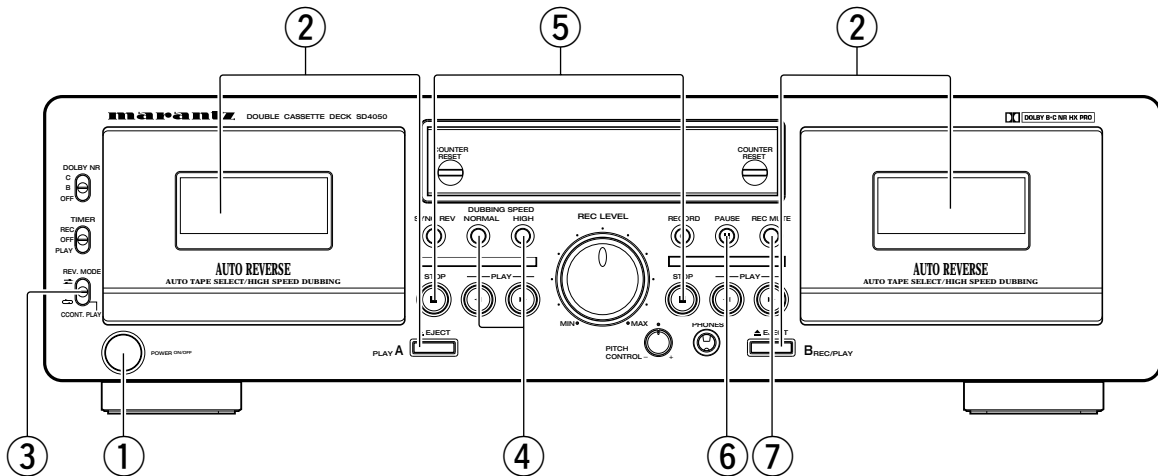

- Press the **POWER** switch ① to the ON () position.
- Load the cassette tape to be played on deck A and the one to be recorded in deck B ②.
- Select the position of the **REV MODE** switch ③.
- To being normal speed dubbing, press the **DUBBING SPEED HIGH** button ④. The **NORM DUB** indicator will light at this time. The **HIGH DUB** indicator will light at this time.
- To stop dubbing, press the **STOP (■)** button ⑤ of deck A or deck B.
 - When dubbing, the recording level and the Dolby NR recording will be the same as those of the playback tape, regardless of the positions of the **REC LEVEL** control and the **DOLBY NR** button.
 - When listening to the playback sound during normal speed dubbing, the **DOLBY NR** switch remains off even if it is pressed.
 - Operation using the **REC MUTE** and **PAUSE (|||)** buttons ⑥, ⑦ of deck B is permitted during normal speed dubbing.



Reverse mode	Operation
	Dubbing is performed only for one side. The decks stop when either deck A or B reaches the end of the tape.
	The tape direction is reversed on each deck when they reach the end of the tape. (This is convenient for dubbing to a tape with a different length.)

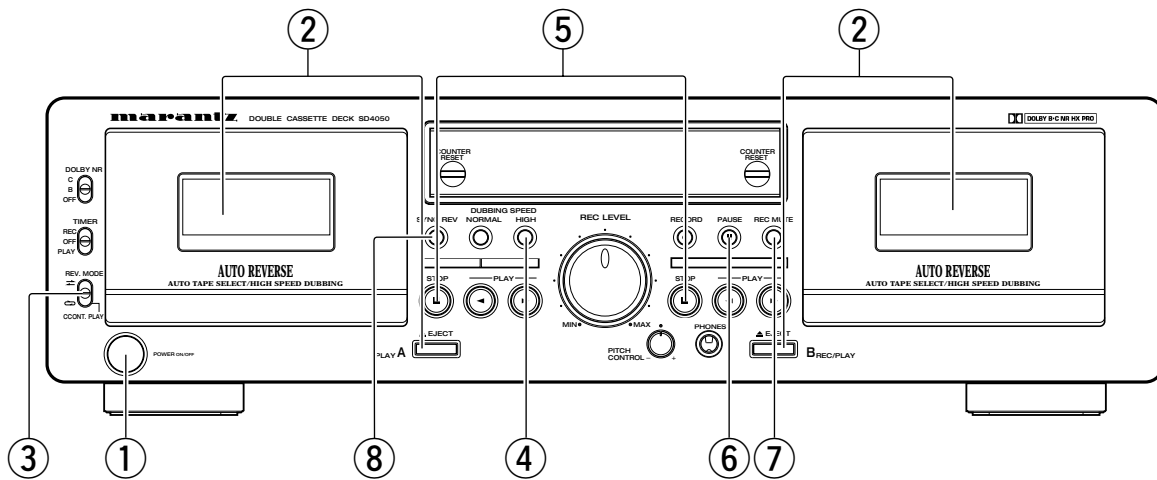

During dubbing of the side facing you, the deck that first reaches the end of the tape will standby until the other deck reaches the end of the tape, direction together.
(Depending on the manufacturer, the length of tapes having the same recording time may differ somewhat. Setting this mode permits the arrangement of the beginning portion of the opposite side of the tape.)

1. Press the **POWER** switch ① to the ON (**■**) position.
2. Load the cassette tape to be played on deck A and the one to be recorded in deck B ②.
3. Select the **↔** position of the **REV MODE** switch ③.
4. Press the **SYNC REV** button ⑧ to set the SYNC REV Mode. The SYNC REV Indicator will light up. To release SYNC REV mode, the **SYNC REV** button is pushed again. When direction of Deck A and Deck B is only Forward (**▶**), the SYNC REV mode can be set.

5. To being normal speed dubbing, press the **DUBBING SPEED NORMAL** button ④. The NORM DUB indicator will light at this time. To high speed dubbing, press the **DUBBING SPEED HIGH** button ④. The HIGH DUB indicator will light at this time.
6. To stop dubbing, press the **STOP** (**■**) button ⑤ of deck A or deck B.
 - When dubbing, the recording level and the Dolby NR recording will be the same as those of the playback tape, regardless of the positions of the **REC LEVEL** control and the **DOLBY NR** button.
 - When listening to the playback sound during normal speed dubbing, the **DOLBY NR** switch remains off even if it is pressed.
 - Operation using the **REC MUTE** and **PAUSE** (**■**) buttons ⑥, ⑦ of deck B is permitted during normal speed dubbing.

SYNCHRO RECORDING PROCEDURE (Deck B)

- The following operation is available only when a MARANTZ CD player with the synchro recording capability is connected to the cassette deck.
- To use synchro recording, connect the remote control cord terminals on the CD player and cassette deck.

1. Load a cassette tape in Deck B.
2. If Dolby NR recording is required, select type B or C.
3. Press the **RECORD/0** button to put the cassette deck in record-pause mode.

4. Adjust the recording level with the **REC LEVEL** control.
 5. Start edit playback of the CD player. (The operation procedure may be variable between CD players with edit function. Refer to the instruction manual of your CD player.)
- When the MARANTZ CD-57, CD-67 or CD6000 CD player is used, be sure to set the **REV. MODE** switch to "=". (This causes both tape sides A and B to be recorded automatically.)
 - When other MARANTZ CD player than the above mentioned models is used, set the **REV. MODE** switch to "-". (This causes only tape side A or B to be recorded.)

TAPE COUNTER

1) Operation of the Tape Counter

- (1) Press the **COUNTER RESET** button to reset the counter to "0000".
- (2) By using the **PLAY**, **FF**, or **REW** functions, the reading of the counter will change to indicate index position.

- During recording and playback operations, the counter is useful for noting the location of existing programs or positions where recording is to be started.
- The reading of this counter does not correspond with that of any other deck.

DOLBY B AND C NOISE REDUCTION SYSTEM

- The Dolby noise reduction system substantially reduces the tape background noise (hiss) inherent in the cassette medium.
- Tape background noise consists primarily of high frequency information, which is particularly annoying during soft passages. The Dolby NR system increases the level of low volume mid and high frequency signals during recording and reduces the level of these signals by an identical amount during playback. As a result, the playback signal is identical to the original source, but the level of background noise generated by the tape is greatly reduced.

- The operating principle of Dolby C NR is similar to that of Dolby B NR except for the encoding/decoding response curves. The noise reduction effect obtained with Dolby C NR is up to 20 dB, compared to 10 dB with Dolby B NR. In addition, Dolby C NR uses an anti-saturation network and spectral skewing circuitry for a significant improvement in the dynamic range of the mid-to-high-frequencies.

DOLBY HX PRO HEADROOM EXTENSION SYSTEM

This deck is equipped with the Dolby HX PRO headroom extension system. Since the system functions automatically during recording, no switching operation or adjustment is required. The system is effective with any type of Normal, High and Metal tape.

The Dolby HX PRO headroom extension system functions during recording to raise the saturation level in the high frequency range. Therefore, most of the high frequency range distorted or lost during recording on conventional cassette decks are more faithfully recorded on the new MARANTZ cassette deck.

Features of the Dolby HX PRO Headroom Extension System

- (1) Performance of Normal and High Position tapes can be improved to very close of that offered by Metal tape.
- (2) The dynamics in the high frequency range are improved significantly.
- (3) Since no decoding is necessary during playback, the improved sound can be enjoyed on any type of tape deck, including portable players and car audio systems.
- (4) The system functions whether the Dolby B/C NR system is engaged or not.

MAINTENANCE

Head cleaning

After long usage, tape coating material or dust may adhere to the heads, causing deterioration of sound. Therefore, the parts depicted in the illustration should be cleaned regularly. Use a cotton swab moistened with a tape head cleaning solution (such as alcohol).

Note:

1. Some cleaning cassettes on the market have strong abrasive effects and may scratch the heads. Always use cotton swabs instead of cleaning cassettes.
2. Since the use of metal tape is apt to collect more dust on the heads, the heads should be cleaned more often to enjoy the best possible sound.

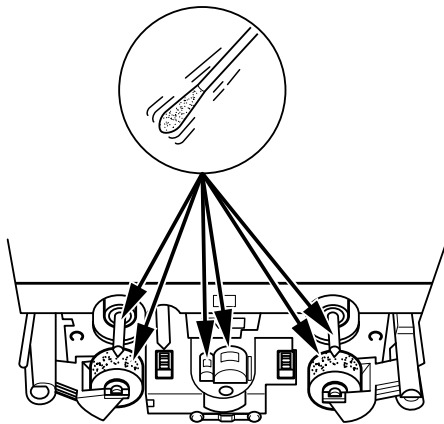

Cleaning the Pinch Rollers and Capstans

If the pinch roller or capstans accumulate dust, tape transport may become unstable, as a result from slippage, during recording or playback. The tape can also be damaged if it gets entangled in the capstan.

Clean these parts with a cotton swab or a soft cloth moistened with a tape head cleaning solution (such as alcohol).

Demagnetizing the Heads

The heads may become magnetized after long usage or if strongly magnetized objects are brought near them. The result is a generation of noise, loss of the high frequency range, and in extreme cases erasure of the high frequency part on pre-recorded tapes in combination with added noise.

Thus, the heads should be demagnetized at regular intervals. (Head demagnetizers are separately available from your dealer.)

How to Demagnetize the Tape Heads

1. Turn off the power.
2. Turn on the demagnetizer while it is at least 30 cm away from the heads. Bring the demagnetizer near the heads and slowly move it in small circles four or five times in front of each head, making sure you do not touch them.
3. Slowly move the demagnetizer away and turn it off when it is at least 30 cm away from the heads.
4. For more details, please read the User Guide provided with the demagnetizer (optional).

CAPABILITY OF REMOTE CONTROL

	RC-5 CODE
PLAY (▶)	1853
FF (▶▶)	1852
REW (◀◀)	1850
PAUSE ()	1848
STOP (■)	1854
REC	1855
REC MUTE	1842
COUNTER RESET	1849
DECK A	1844
DECK B	1846
DIRECTION (◀▶)	1847

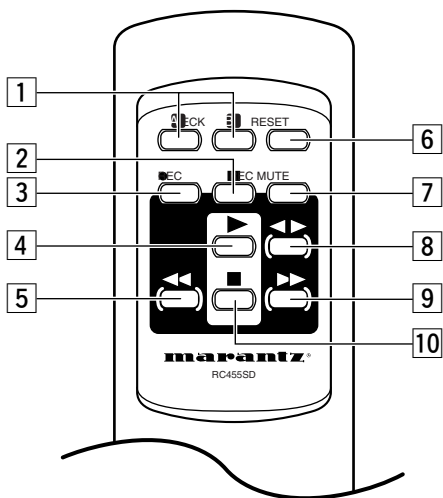

1 A/B button Mechanism select buttons (DECK A/B):

Press to select the deck mechanism, Deck A or Deck B, to be controlled.

2 II (REC PAUSE) button:

Press this button to enter the recording pause mode from the recording or recording mute mode. This button can only be used during recording. See page 9.

3 ● REC button:

Press the REC button, the deck enters the Recording Pause mode. See page 9.

4 ► (Play button):

Press to playback tape.

5 ◀◀ (Fast rewind button):

Press for fast rewind.

6 RESET button:

Press to tape counter reset.

7 REC MUTE button:

Press the REC MUTE button, the Recording Pause mode will start Auto Rec Mute, and a 4-second silent space is recorded onto the tape. See page 9.

8 ◀▶ (DIRECTION) button:

After starting playback, press the forward (►) or reverse (◀) to select the top playback direction.

9 ►► (Fast forward button):

Press for fast forwarding.

10 ■ (STOP) button:

Press to cancel any operation modes and stop the tape travel of the deck.

1. Remote control

Operate the remote control unit (RC455SD) within a distance of approx. 5 m from the infrared signal reception window (remote sensor) on the front of the CASSETTE DECK. Remote control operation may not be possible if the remote control unit's transmitter is not pointing in the direction of the remote sensor or if there is an obstruction between the transmitter and the remote sensor.

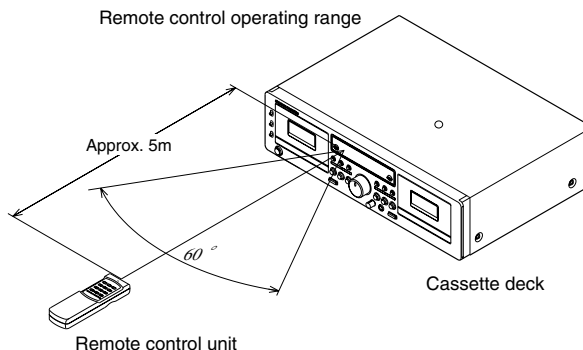

2. Loading batteries

Batteries in this remote control unit have a life of approximately 1 year under normal operating conditions. When the remote control unit is not to be used for an extended period of time, remove the batteries. Also, when you notice that the batteries are starting to run down, replace them as soon as possible.

(1) Remove the battery cover.

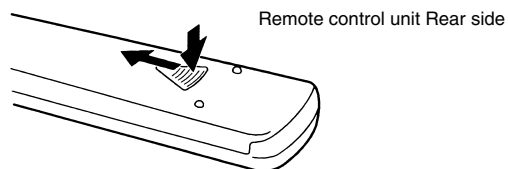

(2) Insert the batteries with correct +/- orientation.

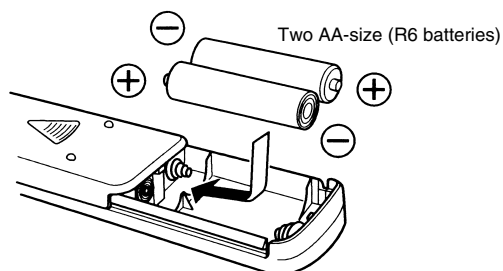

(3) Close the battery cover until it clicks shut.

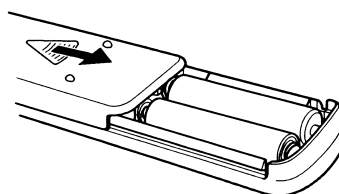

TROUBLESHOOTING

Check the following before you draw the conclusion that your Stereo Cassette Deck is malfunctioning.

1. Are all the connections correct?
 2. Are all system components being operated correctly in accordance with the operating instructions?
 3. Are the speakers and amplifier receiver functioning correctly?
- If the tape deck still does not function properly, check the symptom against the list below. If the symptom does not correspond to the check list, please contact your MARANTZ dealer.

Problem	Cause	Remedy
Tape does not run.	<ul style="list-style-type: none"> ● Power cord is disconnected. ● Tape is loose. ● Cassette is not loaded properly. ● Defective cassette. 	<ul style="list-style-type: none"> ● Check power cord. ● Tighten tape with a pencil, etc. ● Load cassette properly. ● Replace cassette.
Tape is not recorded when REC MUTE button is pressed.	<ul style="list-style-type: none"> ● No cassette is loaded. ● Erase prevention tab is broken off. 	<ul style="list-style-type: none"> ● Load cassette. ● Cover hole with adhesive tape.
Sound is warbled or distorted.	<ul style="list-style-type: none"> ● Heads, capstan or pinch roller are dirty. ● Tape is wound too tight. ● Recording input level is too high. ● Tape is worn out and has "drop-outs". 	<ul style="list-style-type: none"> ● Clean them. ● Fast forward or rewind to loosen tape winding. ● Adjust recording input level. ● Replace tape.
Excessive noise.	<ul style="list-style-type: none"> ● Tape is worn. ● Heads, capstan or pinch roller are dirty. ● Heads are magnetized. ● Recording input level is too low 	<ul style="list-style-type: none"> ● Replace tape. ● Clean them. ● Demagnetize heads. ● Adjust recording input level.
High frequency range (treble) is emphasized.	<ul style="list-style-type: none"> ● Dolby NR switch is set improperly 	<ul style="list-style-type: none"> ● Set Dolby NR switch properly.
High frequency range (treble) is lost.	<ul style="list-style-type: none"> ● Heads are dirty. ● Tape is worn. 	<ul style="list-style-type: none"> ● Clean them. ● Replace tape.
The cassette tape cannot be removed.	<ul style="list-style-type: none"> ● If the POWER switch is turned off either during recording or playback, and the unit is stopped, there may be case when the cassette cannot be removed, even if the EJECT (▲) button is pressed. 	<ul style="list-style-type: none"> ● Turn the POWER switch ON again, and then press the STOP (■) button. Now, press the EJECT (▲) button to remove the cassette tape.

SPECIFICATIONS

Type	Vertical tape loading; 4-track 2-channel stereo double cassette deck	Inputs LINE	100 mV input level at maximum
Heads	Play back head × 1 recording/playback head × 1 Erase head (Double-gap ferrite) × 1	Output LINE	Input impedance: 50 kohms unbalanced 460 mV (0 dB) output level at maximum (with 47 kohms load, recorded level of 200 nWb/mm)
Motors	DC servo motor × 2	PHONES	0.95 mW output level at maximum (optimum load impedance 8 ohms ~ 1.2 kohms)
Tape Speed	4.8 cm/sec. 9.5 cm/sec. (When high speed dubbing)	Power Consumption	0.13 A
Fast Forward, Rewind Time	Approx. 110 sec. with a C-60 cassette	Dimensions	17-7/16 (W) × 5-5/16 (H) × 12-9/16 (D) inches
Recording Bias	Approx. 100 kHz	Weight	440 (W) × 124 (H) × 286 (D) 8.58 lbs oz (4.0 kg)
Overall S/N Ratio (at 3% THD level)	Dolby C NR on: more than 74 dB (CCIR/ARM)		
Overall Frequency Response	25 ~ 18,000 Hz ±3 dB (at -20 dB, Metal tape)		
Channel Separation	More than 40 dB (at 1 kHz)		
Wow & Flutter	0.09 % WRMS, ±0.1 % w. peak		

* Above specifications and design are subject to change without prior notice.

Dolby noise reduction and HX Pro headroom extension manufactured under license from Dolby Laboratories Licensing Corporation. HX Pro originated by Bang & Olufsen.

"DOLBY", the double-D symbol  and "HX PRO" are trademarks of Dolby Laboratories Licensing Corporation.

COUNTRY	COMPANY	ADDRESS
AUSTRALIA	Scan audio Pty. Ltd.	4 Station Street, Thornleigh NSW 2120, Australia
AUSTRIA	Huber & Prohaska GmbH	Taborstraße 95 / Ladestraße 1, Gebäude Hangartner, A-1200 Wien, Austria
BELGIUM	Van der Heyden Audio N.V.	Brusselbaan 278, 9320 Erembodegem, Belgium
BULGARIA	Ariescommerce GmbH	Makedonia Blvd. 16, 1606 Sofia, Bulgaria
CANADA	Lenbrook Industries Limited	633 Granite Court, Pickering, Ontario
CYPRUS	Empire Hifi systems Ltd.	P.O. Box 5604, Nicosia, Cyprus
CZECH REPUBLIC	Audio International	Fugnerova 1, 67801 Blansko, Czech Republic
DENMARK	Hi-Fi Klubben Denmark	Aboulevarden 1, DK-8000 Arhus C., Denmark
DUBAI	V.V. & SONS	P.O. Box 105, Dubai, U.A.E.
ESTONIA	Audio International Baltic	Lo Hu 12, EE0026 Tallin, Estonia
F.Y.R.O.M.	T.P. KODI	ul.Cedomir Kantargiev 21a, Skopje, Former Yugoslavian Republic of Macedonia
FINLAND	Hi-Fi Klubi Finland	Uudenmaankatu 4-6, SF-00120 Helsinki, Finland
FRANCE	Marantz France	A division of Marantz Europe B.V., P.O. Box 301, 92 156 Suresnes Cedex, France
GERMANY	Marantz Deutschland	Hakenbusch 3, 49078 Osnabrück, Germany
GREECE	Adamco S.A.	188, Hippocratous Street, 11471 Athens, Greece
HEADQUARTERS EUROPE:	Marantz Europe B.V.	Building SFF-2, P.O. Box 80002, 5600 JB Eindhoven, The Netherlands
HONG KONG	Marantz Asia Ltd.	Unit 1706, Metroplaza II, 223 Hing Fong Road, Kwai Fong, N.T., Kowloon, Hong Kong
HUNGARY	Infovox Ltd.	Terez Krt.31, 1067 Budapest, Hungary
ICELAND	Radiobudinn HF	Skipholtí 19, P.O. Box 424, 121 Reykjavik, Iceland
INDIA	Marantz India	c/o Philips India Ltd., Plot 80, Bhosari Industrial Estate Pune - 411026, India
IRAN	Home Co.	5th floor no 878 Philips Building Enghelab ave, P.O. 11365/7844 Tehran, Iran
IRELAND	Marantz Ireland	Clonskeagh, Dublin 14, Ireland
ISRAEL	Elmor Ltd.	52 Heh Beiyar Street, Kikar Hamedina, Tel Aviv, Israel
ITALY	Marantz Italy	Via Casati 23, 20052 Monza (Milano), Italy, Servizio Consumatori 1678-20026, Numero Verde
JAPAN	Marantz Japan Inc.	35-1 Sagami Ohno 7-Chome, Sagamihara-shi, Kanagawa 228-8505, Japan
KOREA	Mk Enterprises Ltd.	121-210, 2F Shinhan Bldg., 247-17 Seokyo-dong, Mapo-ku, Seoul, Korea
KUWAIT	alAlamiah Electronics Intl.	P.O. Box 8196, Salmiah 22052, Kuwait
LATVIA	Ace Ltd.	61, LacPlesa Str., Riga LV 1011, Latvia
LEBANON	AZ Electronics S.A., 1,	P.O. Box 11 2833, Beirut, Lebanon
LITHUANIA	A Accapella Ltd.	Ausros, Vartu G5, Pasazo Skg., 2001 Vilnius, Lithuania
MALAYSIA	Wo Kee Hong Electronics Sdn. Bhd.	102 Jalan SS 21/35, Damansara Utama, 47400 Petaling Jaya, Selangordarul Ehsan, Malaysia
MALTA	Doneo Co Ltd.	78 The Strand, Sliema SLM07, Malta
MAURITIUS	SKR Electronics Ltd.	P.O. Box 685, Bell Village, Port Louis, Mauritius
NETHERLANDS	Marantz Trading	A division of Marantz Europe B.V., Building SFF-2, P.O. Box 80002, 5600 JB Eindhoven, The Netherlands
NEW ZEALAND	Scan audio Pty. Ltd.	4 Station Street, Thornleigh NSW 2120, Australia
NORWAY	Hi-Fi Klubben Norway	Lillegrensen 7, N-0159 Oslo, Norway
OMAN	Mustafa & Jawad Trading CO.	P.O. Box 1918, Ruwi, Oman
POLAND	Marantz Polska	Ul. Marszalkowska 45/49, 00-648 Warszawa, Poland
PORTUGAL	Corel2	Comércio de Electrónica Lda., Av. Luís Bivar, No 85 A, 1050 Lisboa, Portugal
PROFESSIONAL EUROPE	Marantz Professional Products	Kingsbridge House, Padbury Oaks, 575-583 Bath Road, Longford, Middlesex UB7 0EH, U.K.
PROFESSIONAL U.S.A.	Marantz Professional Products	Distributed by: Superscope Technologies Inc., 1000 Corporate Blvd. Ste.D, Aurora, Illinois
QATAR	Almana & Partners W.W.L.	P.O. Box 49, Doha, Qatar
REUNION	Vision +	180 Rue du Marechal Leclerc, 97400 Saint Denis, Ile de la Reunion
ROMANIA	Alltrom SRL	Soseaua Bucuresti, Ploiesti 10, Sector 1, Bucharest, Romania
RUSSIA	Trade Company SV	Bld. 2, 7 Montazhnaya Street, 107497 Moscow, Russia
SAUDI ARABIA	Ultimate Fidelity	Sameria Comm. Center, Roadah Dist., P.O. Box 7760, Jeddah 21472, Saudi Arabia
SINGAPORE	Forward Marketing (S) Pte. Ltd.	Wo Kee Hong Centre, 29 Leng Kee Road, Singapore 159099, Singapore
SLOVAKIA	Audio International Slovakia	Nam. SNP 10, 96001 Zvolem, Slovakia
SLOVENIA	Bofex	Smartinska 152, HALA V/3, 61000 Ljubljana, Slovenia
SOUTH AFRICA	Coherent Imports (PTY) Ltd.	P.O. Box 1614, Alberton, 1450, South Africa
SPAIN	Marantz Spain	Martinez Villergas 2, Apartado 2065, Madrid 28027, Spain
SWEDEN	Hi-Fi Klubben A.B.	Tegnersgatan 21, S-412 52 Gotenborg, Sweden
SWITZERLAND	Sound Company AG	Postfach, 8010 Zürich, Switzerland
TAHITI	Covecolor	Av. Prince Hinoi, Cours de l'union sacré, P.O. Box 2334, Papeete, Tahiti
TAIWAN	Pai-Yuing Co. Ltd.	6th No 148 Sung Kiang Road, Taipei 10429, Taiwan R.O.C.
THAILAND	MRZ Standard Co. Ltd.	746-750 Mahachai Road, Wangburapa, Bangkok 10200, Thailand
TURKEY	Penta Elektronik	Sanayi Ve Ticaret Ltd. Sti., Selvi Kokak, No. 4/1, Senliikkoy, 34810 Florya, Istanbul, Turkey
U.K.	Marantz Hifi UK Ltd.	Kingsbridge House, Padbury Oaks, 575-583 Bath Road, Longford, Middlesex UB7 0EH, U.K.
U.S.A.	Marantz America Inc.	440 Medinah Road, Roselle, IL 60172, U.S.A.
YUGOSLAVIA	ITM	Ljutice Bogdana la, Belgrade, Yugoslavia
EXPORT	Marantz Trading	A division of Marantz Europe B.V., Building SFF-2, P.O. Box 80002, 5600 JB Eindhoven, The Netherlands

www.marantz.com

HX Pro headroom extension originated by Bang & Olufsen and manufactured under license from Dolby Laboratories Licensing Corporation.

"DOLBY", the double-D symbol , and "HX PRO" are trademarks of Dolby Laboratories Licensing Corporation.

marantz® is a registered trademark.

